



# Specification for Approval

Customer: \_\_\_\_\_

Model Name: \_\_\_\_\_

Supplier Approval			Customer approval
R&D Designed	R&D Approved	QC Approved	
<i>Peter</i>	<i>Peng Jun</i>		





---

CONTENTS	PAGE
1. Introduction and General Specifications -----	4-7
2. LCD&LCM Outline Drawing -----	8
3. INTERFACE PIN CONNECTIONS -----	9
4. TIMING CHARACTERISTICS OF INPUT SIGNAL -----	10-13
5. ELECTRO-OPTICAL CHARACTERISTICS -----	14-15
6. RELIABILITY -----	16
7. Inspection Standards -----	16-19

## 1. Introduction And General Specifications

Liquid crystal Displays (LCDS) have widely used in many applications such as industrial measurements, office mechanisms, and household electronic-equipment etc. LCM (LCD Module) integrates with LCD and driving circuit that is easily to be interfaced by user. This LCM contains a standard built-in dot -matrix font set.

### 1.1 Applications of LCM

- Telephone
- Facsimile mechanism
- Electronic Typewriter
- Word processor
- Electronic memo pads
- Remote controller

### 1.2 Features of LCM

- Compact, thin and light
- Wide view angle
- Low power consumption
- High contrast image
- Wide operating temperature
- High reliability

### 1.2 General specification

Parameter	Value	Unit
Size	4.3" inch	
Module outline (W x HxD)	105.4X67.1X2.9	
Active area (WxH)	95.04 x 53.86	
Display Resolution	480*RGB*272	pixels
Pixel Arrangement	RGB-stripe	-
Viewing Direction	6 o' clock	
Display Mode	Normally white TN	
IC Package Type	COG	-
Suggesting IC	OTA5180A	
Interface Type	RGB 24-bit	-
Power Supply Voltage	2.8~3.3	V
Back-light	White LED*10	pcs
Operation Temperature	-20~70 °C	
Storage Temperature	-30~80 °C	

### 1.3 Absolute Maximum Ratings

Rating	Symbol	Value		Unit
Digital supply voltage	VDDIO	-0.3	to +4.5	V
Power Supply for Pump	VDD	-0.3	to +4.5	V
Analog supply voltage	VDD2	-0.3	to +7.0	V
Storage temperature	T <sub>STG</sub>	-55	to 100	°C
Operating temperature	T <sub>A</sub>	-30	to 85	°C

**Note:** Stresses beyond those given in the Absolute Maximum Rating table may cause operational errors or damage to the device. For normal operational conditions see AC/DC Electrical Characteristics.

### 1.4 Recommended Operating Range

Item	Symbol	Min.	Typ.	Max.	Unit	Conditions
Charge Pump Supply Voltage	PVDD	3	3.3	3.6	V	PWR_SEL=H
	PVDD	2.25	2.5	3	V	PWR_SEL=L
Digital Supply Voltage	VDD	3	3.3	3.6	V	PWR_SEL=H
	VDD	2.25	2.5	3	V	PWR_SEL=L
Digital Interface Supply Voltage	VDDIO	1.65	1.8	VDD	V	
Digital Input Voltage	Din	0	-	VDDIO	V	
OTP Supply Voltage	V_OTP	7.4	7.5	7.6	V	
VCOM AC Voltage	VCOMH- VCOML	3.46	-	6.2	V	

### 1.5 DC Characteristics for Digital Circuit

VDDIO=1.8V, VDD = 3.3V, AVDD = 6V, AGND = 0V, T<sub>A</sub> = -20°C to 80°C

Item	Symbol	Min.	Typ.	Max.	Unit	Conditions
Low Level Input Voltage	V <sub>IL</sub>	GND	-	0.3xVDDIO	V	
High Level Input Voltage	V <sub>IH</sub>	0.7xVDDIO	-	VDDIO	uA	
High Level Output Voltage	V <sub>OH</sub>	VDDIO-0.4	-	VDDIO	ohm	
Low Level Output Voltage	V <sub>OL</sub>	GND	-	GND+0.4	uA	
Input Leakage Current	I <sub>II</sub>			±1.0		
Pull High/Low Resistor	R <sub>p</sub>	-	100K	-	ohm	
Digital Stand-by Current	I <sub>st</sub>		5.0	20	uA	DCLK stopped, Output HI-Z
Digital Operating Current	I <sub>cc</sub>	-	4	-	mA	DCLK = 9MHz

## 1.6 Electrical Characteristics

VDDIO=1.8V, VDD = 3.3V, AVDD = 6V, AGND = 0V, T<sub>A</sub> = -20°C to 80°C

Item	Symbol	Min.	Typ.	Max.	Unit	Conditions
Analog Supply Voltage	VDD2		5		V	
Positive High-voltage power	VGH	9	15	16	V	No Load. By VGH_SEL setting.
Negative High-voltage power	VGL	-11	-10	-7	V	No Load. By VGL_SEL setting.
VCOMH Output Level	VCOMH	3.26		5.8	V	By VCOMH setting.
VCOML Output Level	VCOML	-2		-0.2	V	By VCOML setting.
DRV Output Voltage	VDRV	0	-	VDD	V	
DCDC Feed Back Voltage	VFB	0.28	0.6	0.79	V	By LED_VFB setting
Base Drive Current	IDRV	-	20	25	mA	By LED_VFB setting
Output Voltage Deviation	Vod	-	±20	±35	mV	V <sub>O</sub> = 0.15V ~ 0.5V, 3.45V~3.8V
		-	±15	±20		V <sub>O</sub> = 0.5V ~ 3.45V
Output Dynamic Range	Vdr	0.2	-	5.3		MVA Mode
		0.15		4.8		TN Mode
VCOM Low Level Output Current	IOL <sub>FBP</sub>		-10		mA	VCOM AC output = 0.5V
VCOM High Level Output Current	IOM <sub>FBP</sub>		-10		mA	VCOM AC output = 5.7V
Analog Standby Current	I <sub>ast</sub>	-	-	20	uA	
Analog Operation Current	IDD	-	5.0	-	mA	Without panel loading

## 1.7 AC Characteristics

VDDIO=1.8V, VDD = 3.3V, AVDD = 6V, AGND = 0V, T<sub>A</sub> = -20°C to 60°C

Item	Symbol	Min.	Typ.	Max.	Unit	Conditions
CLK pulse duty	T <sub>cw</sub>	40	50	60	%	
Hsync width	T <sub>hw</sub>	1.0	-	-	DCLK	
Hsync period	T <sub>h</sub>	55	60	65	us	
Vsync setup time	T <sub>vst</sub>	12	-	-	ns	
Vsync hold time	T <sub>vhd</sub>	12	-	-	ns	
Hsync setup time	T <sub>hst</sub>	12	-	-	ns	
Hsync hold time	T <sub>hhd</sub>	12	-	-	ns	
Data set-up time	T <sub>dsu</sub>	12	-	-	ns	
Data hold time	T <sub>dhd</sub>	12	-	-	ns	
SD output stable time	T <sub>st</sub>	-	10	12	us	
GD output rise and fall time	T <sub>gst</sub>	-	500	1000	ns	
<b>Serial communication</b>						
Delay between CSB and Vsync	T <sub>cv</sub>	1			us	
CS input setup time	T <sub>s0</sub>	50			ns	
Serial data input setup time	T <sub>s1</sub>	50			ns	
CS input hold time	T <sub>h0</sub>	50			ns	
Serial data input hold time	T <sub>h1</sub>	50			ns	
SCL pulse high width	T <sub>wh1</sub>	50			ns	
SCL pulse low width	T <sub>wl1</sub>	50			ns	
CS pulse high width	T <sub>w2</sub>	400			ns	

## 1.8 LCM And Backlight Driving Conditions

Item	Symbol	Values			Unit	Remark
		Min.	Typ.	Max.		
LED forward voltage	V <sub>L</sub>	15	15.5	-	V	Note 2,3
LED forward current	I <sub>L</sub>	-	40	-	mA	Note 3
LCD forward current	I <sub>L</sub>	-	56	-	mA	
LED life time	-	20,000	-	-	Hr	Note 1
LCM Luminance	L <sub>v</sub>	-	300		cd/m <sup>2</sup>	

Note 1: The “LED life time” is defined as the module brightness decrease to 50% original brightness that the ambient temperature is 25°C and I<sub>L</sub> =40mA. The LED lifetime could be decreased if operating I<sub>L</sub> is larger than 40 mA.

Note 2: The LED Supply Voltage is defined by the number of LED at T<sub>a</sub>=25°C and I<sub>L</sub> =40mA. In the case of 5pcs LED , V<sub>L</sub>=3.1\*5=15.5V

Note 3: The LED driving condition is defined for each LED module (5LED Serial 2 parallel).

## 2. LCD&LCM Outline Drawing

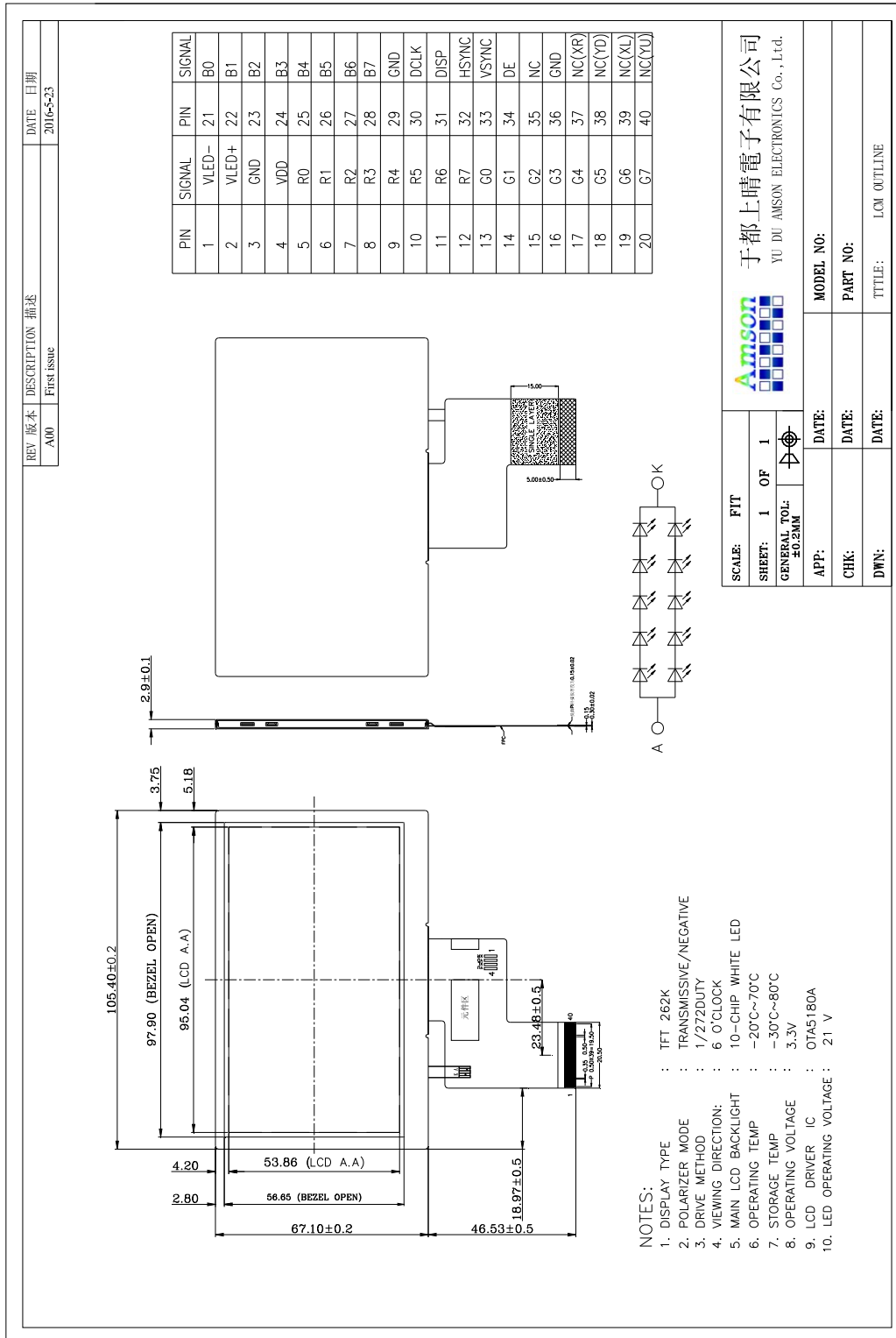

### 3. INTERFACE PIN CONNECTIONS

PIN NO.	SYMBOL	DESCRIPTION
1	VLED-	Backlight LED power supply ( cathode)
2	VLED+	Backlight LED power supply (Anode)
3	GND	Ground
4	VDD	Power Supply
5-12	R0-R7	Red data bit line,(对于16bpp显示模式, RGB=5:6:5时, R0-R2: NC, R7为高位).
13-20	G0-G7	Green data bit line, (对于 16bpp 显示模式, RGB=5:6:5 时, G0-G1: NC, G7 为高位).
21-28	B0-B7	Blue data bit line, (对于16bpp显示模式, RGB=5:6:5时, B0-B2: NC, B7为高位).
29	GND	Ground
30	DCLK	Clock signal, The input data is latched on the rising edge of CLK.
31	DISP	NC
32	HSYNC	In external interface mode, served as a horizontal synchronizing signal input;
33	VSYNC	In external interface mode , served as a vertical synchronizing signal input;
34	DE	Data Enable
35	NC	Not Connected
36	GND	Ground
37	NC	Not Connected
38	NC	Not Connected
39	NC	Not Connected
40	NC	Not Connected

#### 4. TIMING CHARACTERISTICS OF INPUT SIGNAL

##### 4.1 Parallel RGB input timing table

Item	Symbol	Min.	Typ.	Max.	Unit		
DCLK Frequency	Fclk	5	9	12	MHz		
DCLK Period	Tclk	83	110	200	ns		
Hsync	Period Time	Th	490	531	605	DCLK	
	Display Period	Thdisp		480		DCLK	
	Back Porch	Thbp	8	43		DCLK	By H_BLANKING setting
	Front Porch	Thfp	2	8		DCLK	
	Pulse Width	Thw	1			DCLK	
Vsync	Period Time	Tv	275	288	335	H	
	Display Period	Tvdisp		272		H	
	Back Porch	Tvbp	2	12		H	By V_BLANKING setting
	Front Porch	Tvfp	1	4		H	
	Pulse Width	Tvw	1	10		H	

#### SYNC Mode Timing Diagram (Default)

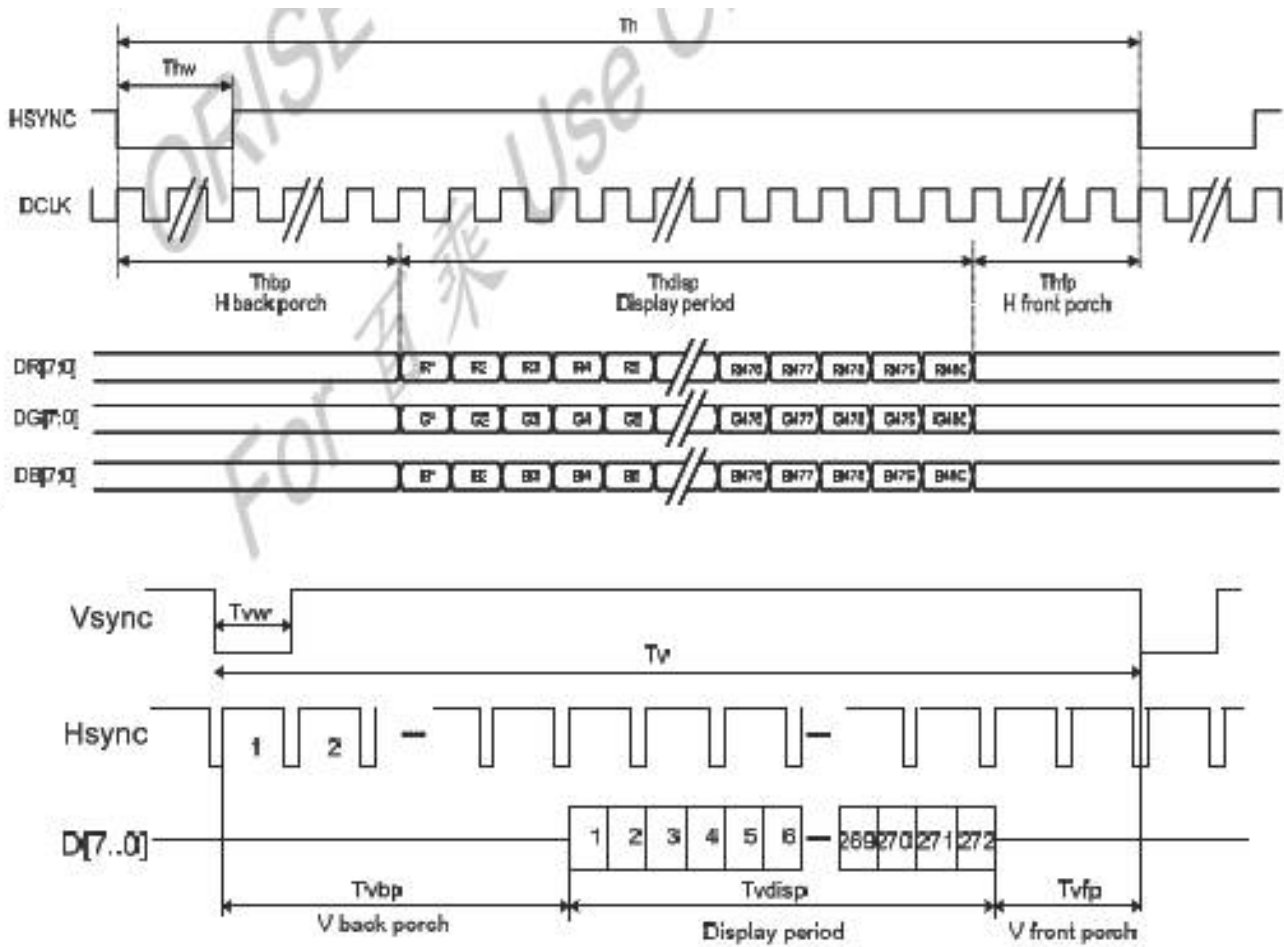

SYNC-DE Mode Timing Diagram

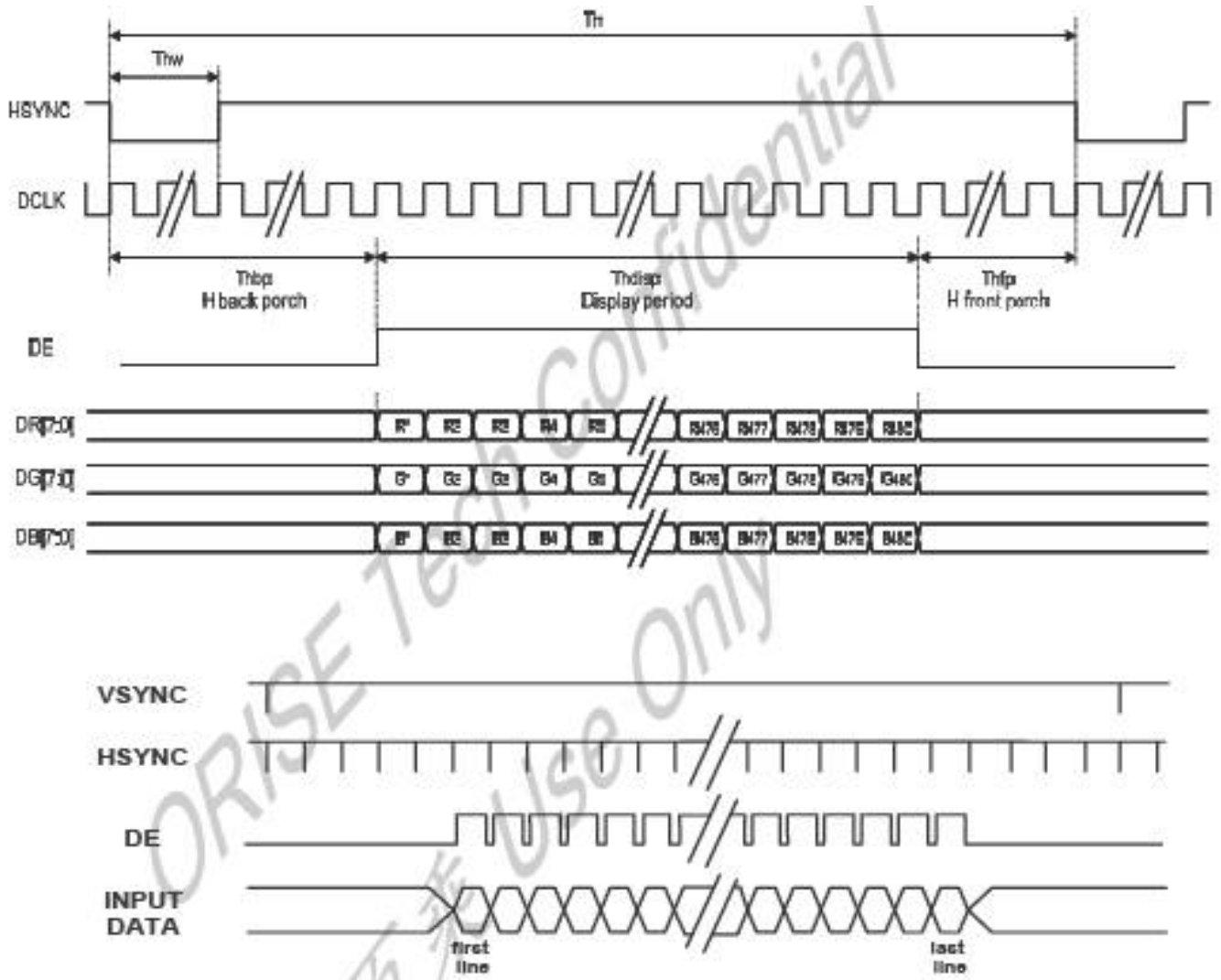

## 4.2 POWER ON/OFF SEQUENCE

### Power ON Sequence

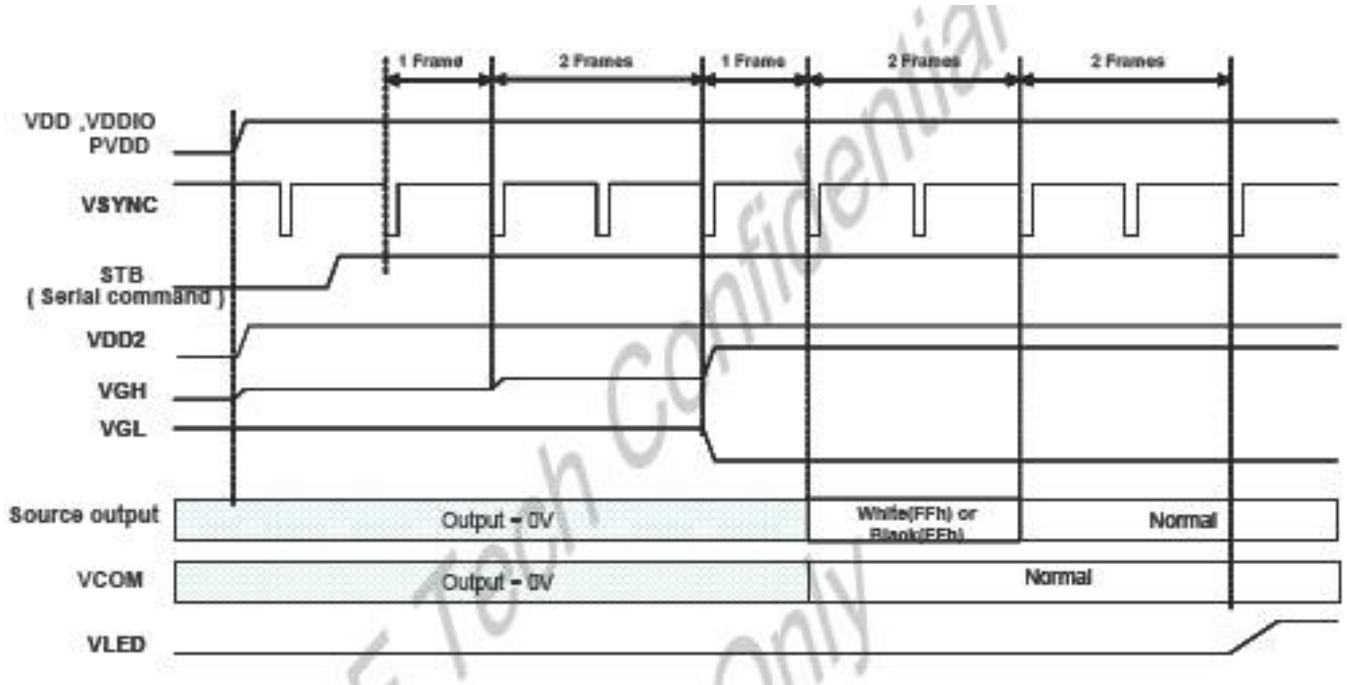

### Power OFF Sequence

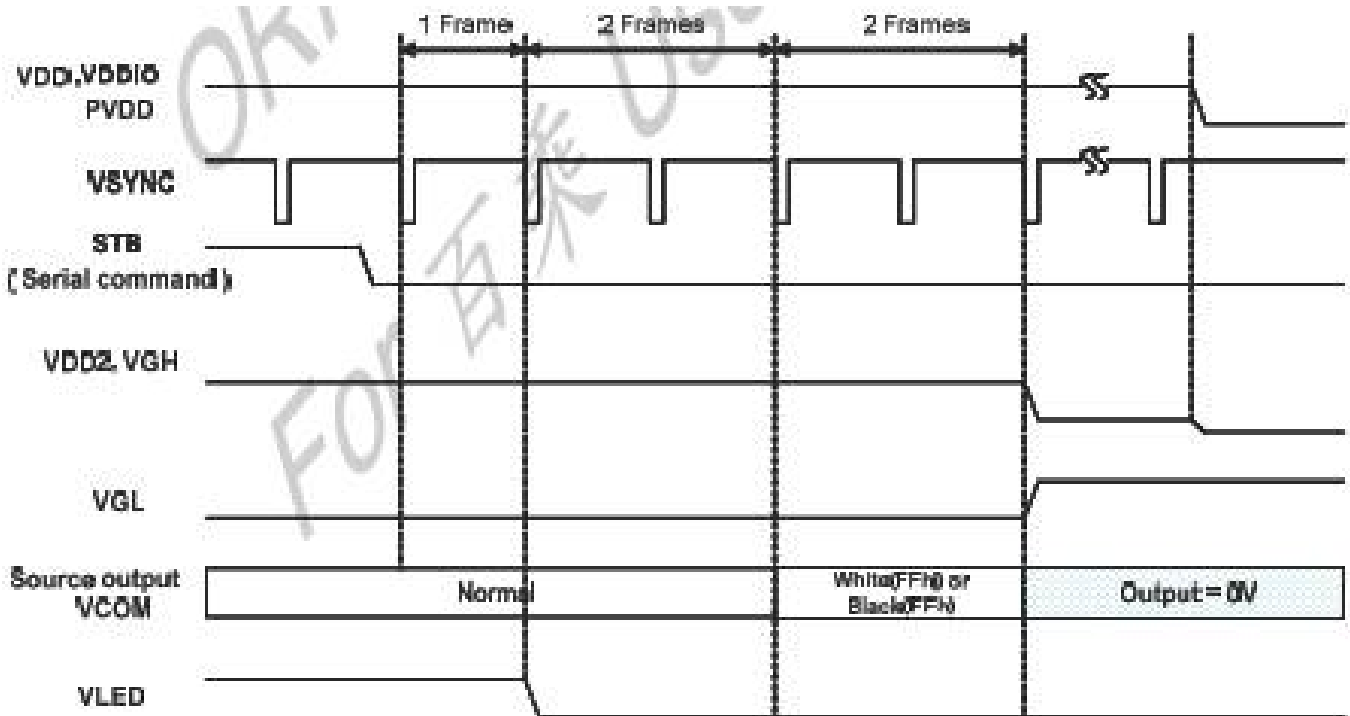

### 4.2.1 Timing Diagram of interface Signal Clock and Data Input Timing Diagram

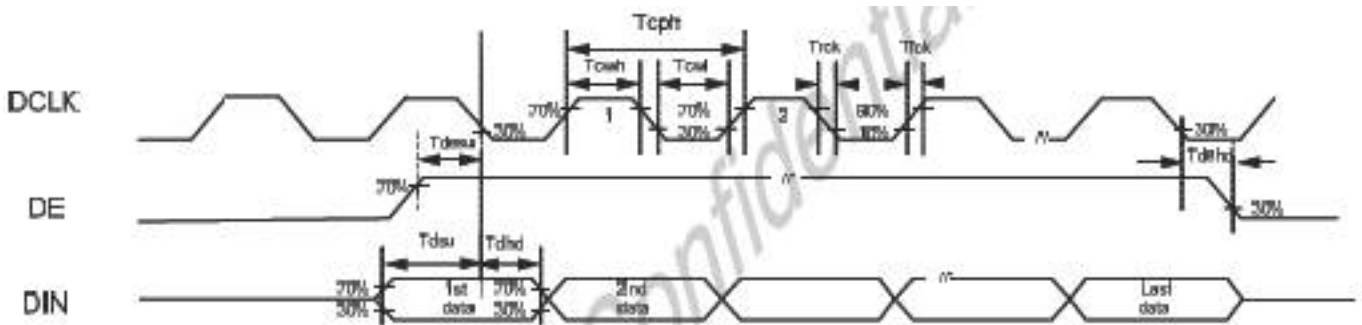

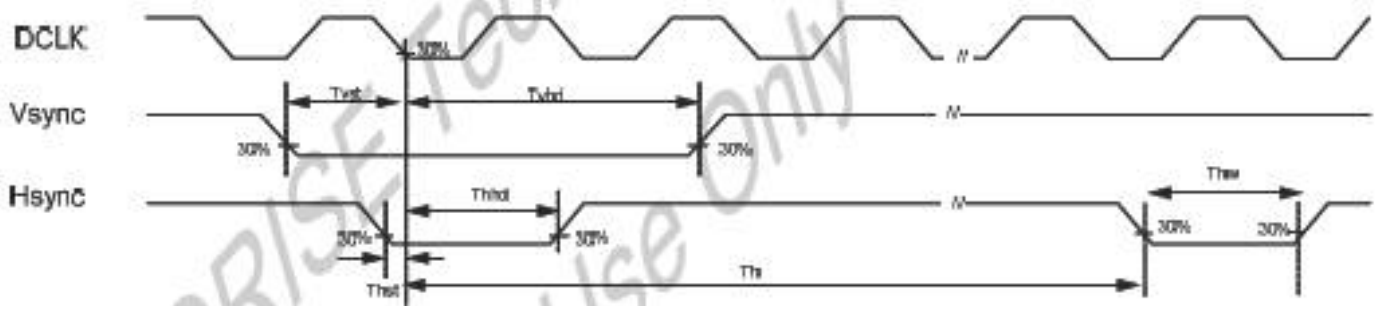

**5. ELECTRO-OPTICAL CHARACTERISTICS**

ITEM	SYMBOL	CONDITION	MIN.	TYP.	MAX.	UNIT	REMARK
Transmittance	T		5.6	5.9		%	Note 2
Contrast Ratio	CR	*1)	250	350	--	--	Note 3
Response Time	Tr+ Tf	*3)	-	30	45	ms	Note 4
Viewing Angle	Vertical	$\theta$ *2)	CR $\geq$ 10	130	150	--	Note 5
	Horizontal	$\phi$ *2)		140	160	--	
Color Filter Chromacicity with C light	White	x y	$\theta = \phi = 0^\circ$	0.282	0.302	0.322	Note 6
				0.318	0.338	0.358	
	Red	x y	$\theta = \phi = 0^\circ$	0.586	0.606	0.626	
				0.305	0.325	0.345	
	Green	x y	$\theta = \phi = 0^\circ$	0.283	0.303	0.323	
				0.547	0.567	0.587	
Blue	x y	$\theta = \phi = 0^\circ$	0.127	0.147	0.167		
			0.121	0.161	0.181		
NTSC			-	50%	-		

Note 1. Ambient condition :  $25^\circ\text{C} \pm 2^\circ\text{C}$  ,  $60 \pm 10\% \text{RH}$  , under 10 Lux in the darkroom  
 Note 2. Measure device : BM-5A (TOPCON) , viewing cone =  $2^\circ$  ,  $I_L = 20 \text{mA}$  .

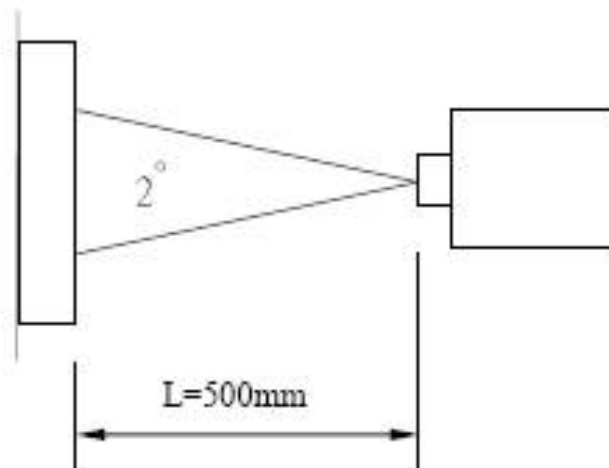

Note 3. Definition of Contrast Ratio :  
 $\text{CR} = \text{White Luminance (ON)} / \text{Black Luminance (OFF)}$

Note 4. Definition of response time : The response time is defined as the time interval between the 10% and 90% amplitudes.

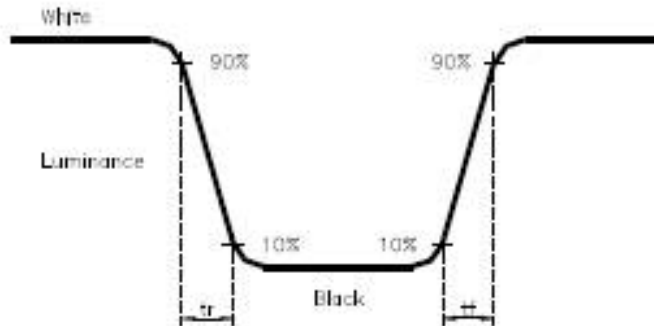

Note 5. Definition of view angle( $\theta$  ·  $\psi$ ) :

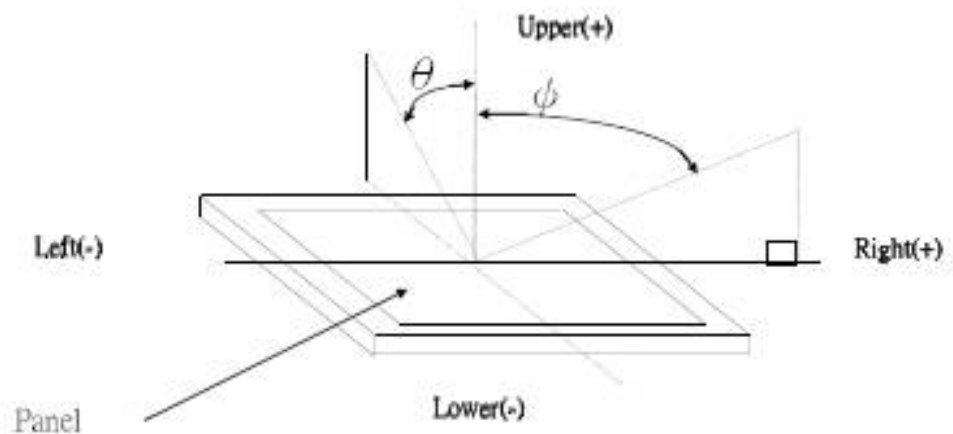

Note 6. Light source: C light.

## 6. RELIABILITY

### 6.1 MTBF

The LCD module shall be designed to meet a minimum MTBF value of 50000 hours with normal. (25° C in the room without sunlight)

### 6.2 TESTS

NO.	TEST ITEM	CONDITIONS
1	High Temperature Storage	80 °C ; 240 hrs
2	Low Temperature Storage	-30 °C ; 240 hrs
3	HighTemperature Operation	70° C ; 240 hrs
4	Low Temperature Operation	- 20 °C ; 240 hrs
5	High Temperature and High Humidity Operation	80 °C, 90% RH ; 240 hrs
6	Thermal Shock	-30°C ~ +80°C , 0.5Hr ; 200 cycles

#### NOTE

1. All judgement of display are performed after temperature of panel return to room temperature.
2. Display function should be no change under normal operating condition.
3. Under no condensation of dew.
4. CPT only guarantee the above 5 test items, and without guarantee the others.

## 7. Inspection Standards

### 7.1 Inspection Conditions

#### 7.1.1 Environmental conditions

The environmental conditions for inspection shall be as follows

Room temperature:  $20 \pm 3$  ° C ; Humidity:  $65 \pm 20\%RH$

#### 7.1.2 The external visual inspection

With a single 20-watt fluorescent lamp as the light source, the inspection was in the distance of 30cm or more from the LCD to the inspector's eyes .

## 7.2 Classification of defects

### 7.2.1 Major defect

A major defect refers to a defect that may substantially degrade usability for product applications.

### 7.2.2 Minor defect

A minor defect refers to a defect which is not considered to be able substantially degrade the product application or a defect that deviates from existing standards almost unrelated to the effective use of the product or its operation.

## 7.3 检验条件

眼睛距离产品 **35-40cm** 以产品法线为中心上下左右 **45°** 进行检查，见下图：

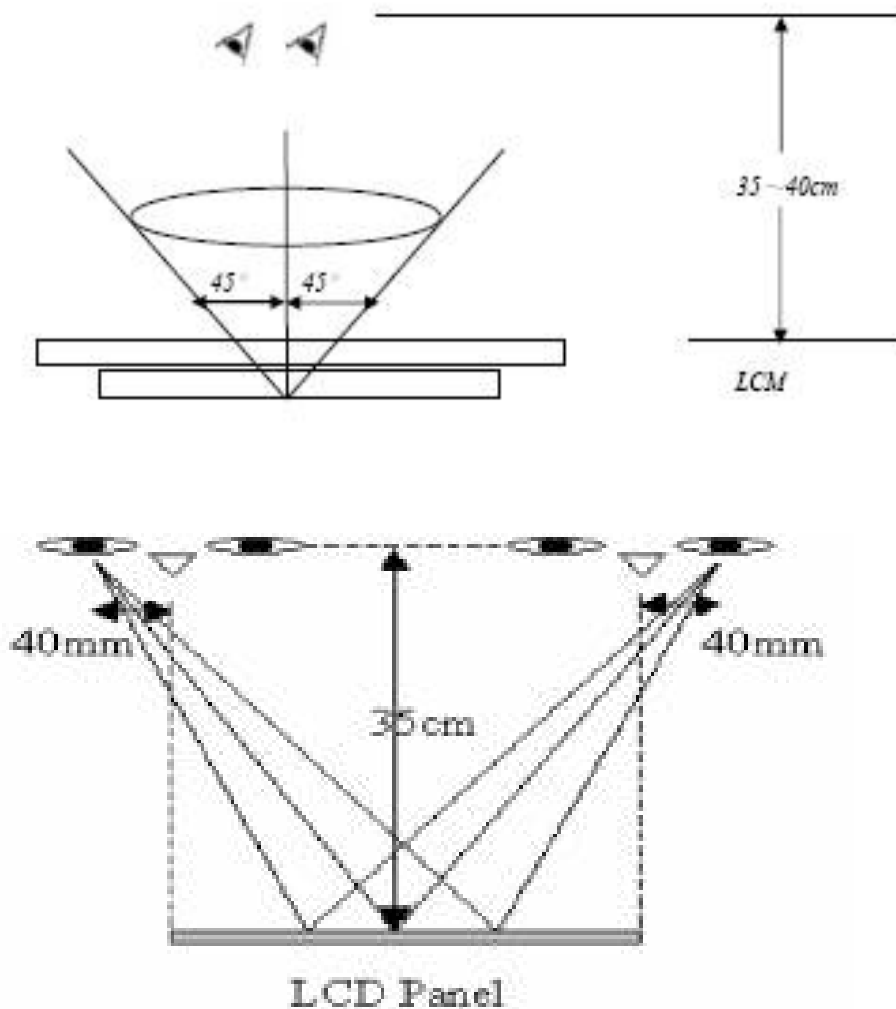

### 7.4 显示区A 区与B 区的定义

**A区**：以屏四边为基准各向屏中心点延伸  $1/4$  区域，所剩下的中心区域视为 **A区**（如下图所示），  
**B区**：以屏四边为基准各向屏中心点延伸  $1/4$  的区域，视为 **B区**（如下图所示）

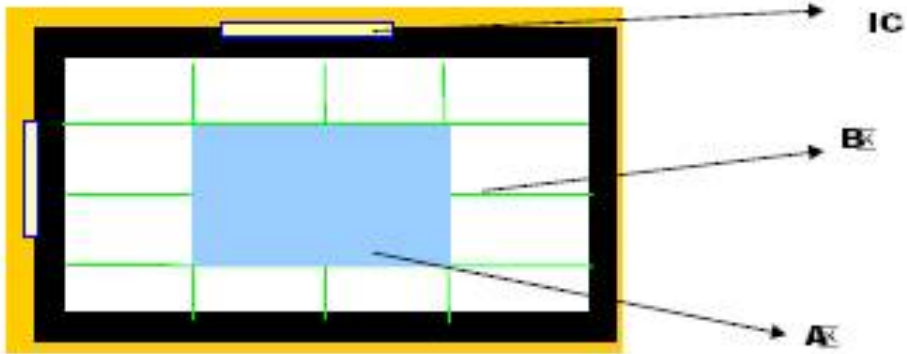

### 7.5 检验标准

项目	现象描述	判定标准			缺陷	备注	
点缺陷	点状：LDTP/偏光片黑点，彩点，亮点	$\Phi$ =直径 $\Phi \leq 0.2m$ 忽略不计 $0.2m < \Phi \leq 0.4m$ 可接收 3个（间隔大于 10m） $\Phi > 0.4m$ 不可接收			ng	/	
		点状数要求	A区	B区			点数总计
		亮点	$N \leq 0$	$N \leq 2$			$N \leq 2$
		暗点	$N \leq 2$	$N \leq 3$			$N \leq 3$
		合计点	$N \leq 2$	$N \leq 3$			$N \leq 4$

		两个连点	N≤0	N≤1	N≤1		
线缺陷	LCD/偏光片/TP/黑白点,线状划伤,线状异物	W≤0.05mm 0.05mm<W≤0.10mm W>0.10mm	忽略不计	L≤10mm 允许3个	L>10mm 不接收	Mag	//
缺划	在任意画面看到的横线、纵线的缺失	Not Allowed				NG	/
画面异常	所有的画面异常主要如下: ※ 横竖与整屏不一致 ※ 部分不显示或显示部分出现闪烁等	Not Allowed				NG	/
残影/阴影	后一画面会留前一画面的影像(影像残留)	残影不良超过5秒不消失为NG				NG	/
画面闪烁	检验时出现画面忽亮忽暗或跳动现象	Not Allowed				NG	/
静电线	影响画面或产品特性之静电线,一般表示为某个画面出现	Not Allowed				NG	/
漏光	灯前有光源或者光束	依客户签样为准				NG	/
	组合缝隙漏光	依客户签样为准				NG	/
灯眼	点亮后 LED灯仔发光区域比其它区域要特别亮	Not Allowed				NG	/
LED亮	点亮时 LED灯不亮	Not Allowed				NG	/
	LED灯点亮闪烁	Not Allowed				NG	/