



Specification for Approval

Customer: _____

Model Name: _____

Supplier Approval			Customer approval
R&D Designed	R&D Approved	QC Approved	
<i>Peter</i>	<i>Peng Jun</i>		



Contents

No.	Item	Page
0	Record of Revision	3
1	Summary	4
2	Features	4
3	General Specifications	4
4	Absolute Maximum Rating	4
5	Electrical Characteristics	5
6	AC Characteristics	6~8
7	Optical Characteristics	9~11
8	Interface	13
9	Block Diagram	14
10	Quality Assurance	15
11	Outline Drawing	16
12	Precautions	17~18



Record of Revision

Version	Date	Page	Section	Description
A	2013/04/19	all	all	Brief Spec New Creation

1. Summary

This technical specification applies to 7" TFT-LCD module with a LED Backlight unit a touch panel and a 40-pin TTL interface. This module supports 800*R.G.B x 480 WVGA mode and can display 262,144 colors.

2. Features

- Thin and Light Weight.
- WVGA(800x480 pixels) resolution.
- 3.3 V TTL interface

3. General Specifications

No.	Item	Specification	Unit
1	Screen Size	7"(Diagonal)	inch
2	Display Resolution	800 RGB x 480	pixel
3	Dot Pitch	63.5 x 190.5	um
4	Pixel Pitch	190.5 x 190.5	um
5	Active Area	152.4x91.44	mm
6	Outline Dimension	165(W) x 104.44(H) x5.2(D)	mm
7	Pixel Configuration	RGB Vertical Stripe	--
8	Color Depth	262,144	colors
9	LCD Type	TN	--
10	Interface Type	TTL	--
11	View direction (Gray inversion)	6 o'clock	--
12	Weight	178.5	g

4. Absolute Maximum Rating

Item	Symbol	Values		Unit	Note
		Min.	Max.		
Storage Temperature	T _{ST}	-30	80	°C	
Operation Temperature	T _{OP}	-20	70	°C	
Digital Power Supply Voltage	V _{CC}	-0.3	6	V	
Input Logic Voltage	V _{IN}	-0.3	V _{CC} +0.3	V	Note 1

Note1: CLK, DE, R0~ R5, G0~ G5, B0~ B5

5. ELECTRICAL CHARACTERISTICS

5.1 Recommended Operation condition (GND=0V , Ta=25°C)

Parameter	Symbol	Rating			Unit	Condition	
		Min.	Typ.	Max.			
Power Supply Voltage	V _{CC}	3.0	3.3	3.6	V		
Input logic voltage	High Level	V _{IH}	0.7V _{CC}	-	V _{CC}	V	Note 1
	Low Level	V _{IL}	0	-	0.3V _{CC}	V	Note 1

Note 1: CLK, DE, R0~ R5, G0~ G5, B0~ B5.

5.2 LED Driving Conditions

Ta = 25°C

Parameter	Symbol	Min.	Typ.	Max.	Unit	Remark
LED current	I _{LED}	-	160	-	mA	Note 1
LED voltage	V _{LED}	-	9.9	-	V	
LED Life Time	-	10,000	20,000	-	Hr	Note 2

Note 1 : There are 8 Groups LED shown as below , V_{LED}=9.9V , I_{LED}=160mA.

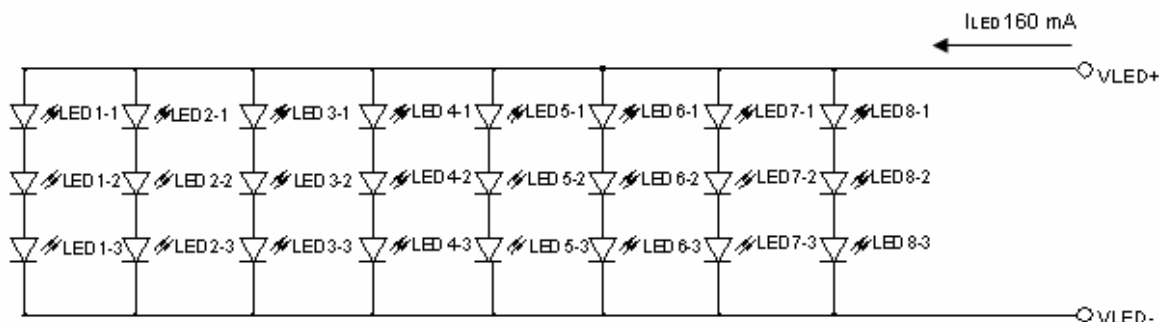

Note 2 : Brightness to be decreased to 50% of the initial value.

5.3 TFT-LCD current consumption

Parameter	Symbol	Rating			Unit	Condition
		Min.	Typ.	Max.		
LCD power current	I _{CC}	--	200	260	mA	black pattern
LED power current	I _{LED}	--	160	200	mA	

6. AC CHARACTERISTICS

6.1 AC Electrical CHARACTERISTICS

Frame rate range : 60Hz~65Hz

Parameter	Symbol	Rating			Unit
		Min.	Typ.	Max.	
Data setup time	Tdsu	6	-	-	ns
Data hold time	Tdhd	6	-	-	ns
DE setup time	Tesu	6	-	-	ns
CLK frequency	F _{CPH}	29.40	33.26	42.48	MHz
CLK period	T _{CPH}	23.54	30.06	34.01	ns
CLK pulse duty	T _{CWH}	40	50	60	%
CLK pulse duty	T _{CWL}	40	50	60	%
DE period	T _{DEH} +T _{DEL}	1000	1056	1200	T _{CPH}
DE pulse width	T _{DEH}	-	800	-	T _{CPH}
DE frame blanking	T _{DEB}	10	45	110	T _{DEH} +T _{DEL}
DE frame width	T _{DE}	-	480	-	T _{DEH} +T _{DEL}

Note : We suggest using the typical value, so it can have better performance.

6.2 Timing Controller Timing Chart

Clock and Data input waveforms

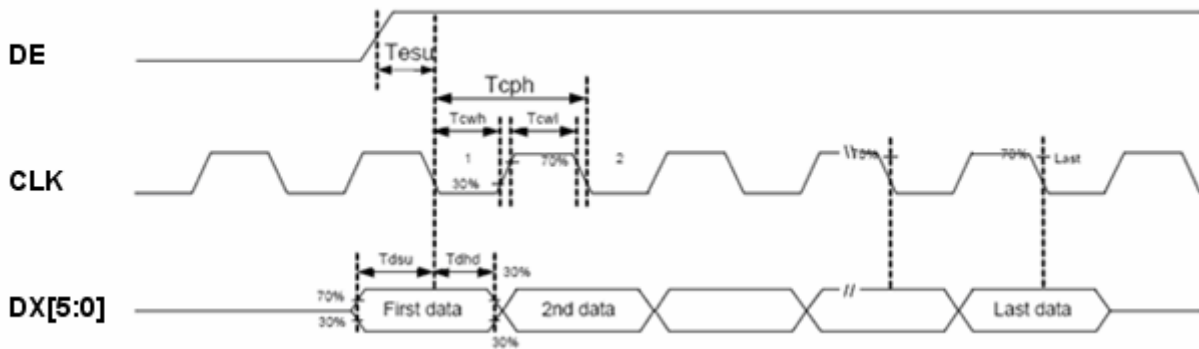

6.3 Data input format

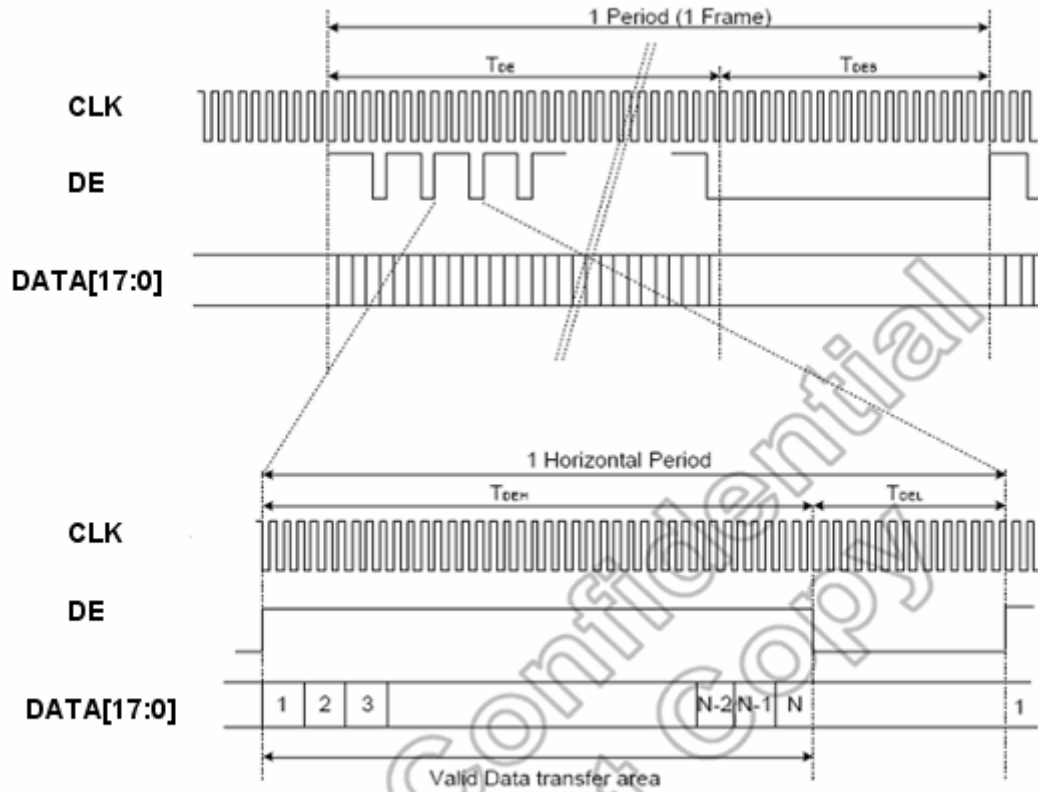

6.4 Power ON/OFF sequence

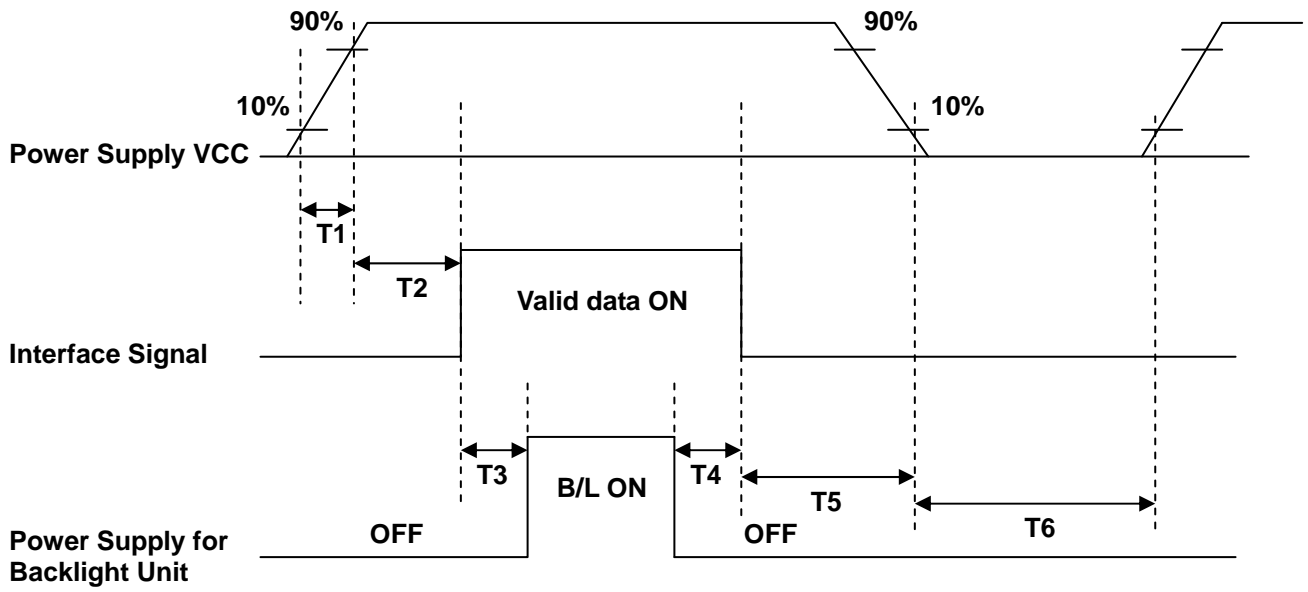

Parameter	SPEC.			Unit
	Min.	Typ.	Max.	
T1	1		2	ms
T2	0	60		ms
T3	200			ms
T4	200			ms
T5	1			ms
T6	1000			ms

7. Optical Characteristics

($T_a = 25 \pm 2^\circ\text{C}$, $I_F=20\text{mA}$)

Item	Symbol	Conditions	Specifications			Unit	Note	
			Min.	Typ.	Max.			
Contrast Ratio	CR	Viewing normal angle $\theta = 0^\circ$ $\phi = 0^\circ$ B/L On	250	400	--	--	(2),(4),(6)	
Brightness	B		250	300	--	cd/m ²		
Response time	T_r		--	5	10	ms	(3)	
	T_f		--	15	20	ms		
Chromaticity	Red		X_R	0.51	0.56	0.61	--	(2)(5)(6)
			Y_R	0.32	0.37	0.42	--	
	Green		X_G	0.28	0.33	0.38	--	
			Y_G	0.51	0.56	0.61	--	
	Blue		X_B	0.10	0.15	0.20	--	
			Y_B	0.06	0.11	0.16	--	
	White	X_W	0.25	0.30	0.35	--		
		Y_W	0.28	0.33	0.38	--		
Viewing Angle	Hor.	θ_L	60	70	--	deg.	(1)	
		θ_R	60	70	--			
	Ver.	ϕ_T	50	60	--			
		ϕ_B	60	70	--			
NTSC	--	--	--	45	--	%		
Uniformity	--	--	70	80	--	%	(7)	

Note:

(1) Definition of viewing angle range

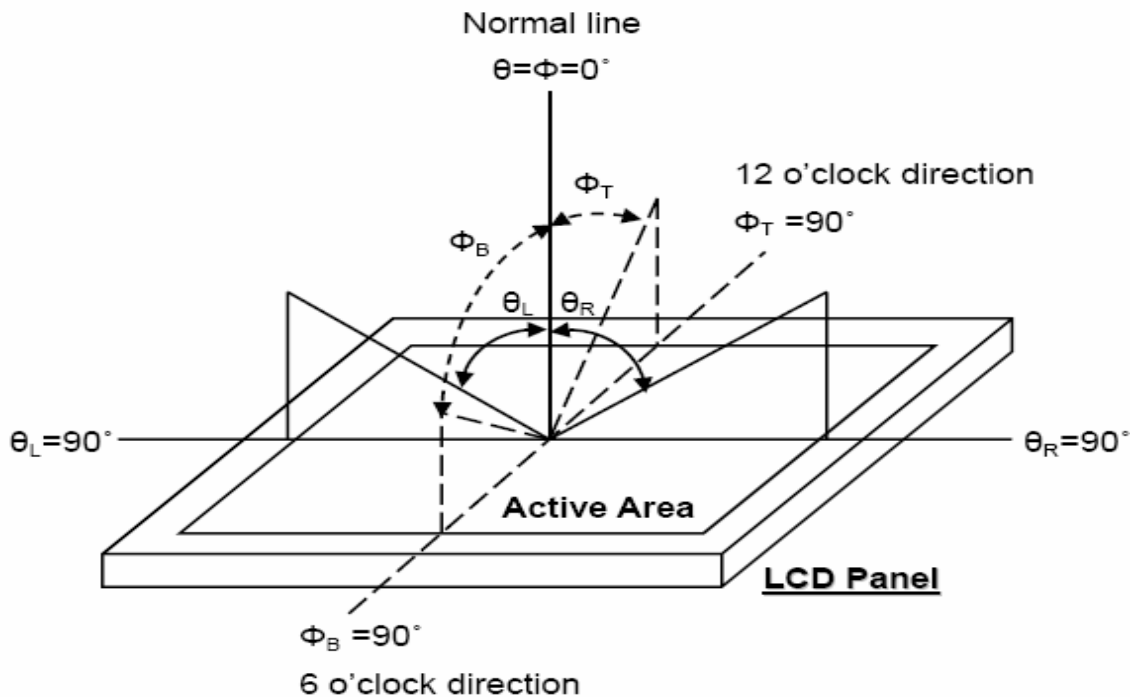

Fig. 8-1 Definition of viewing angle

(2) Test equipment setup:

After stabilizing and leaving the panel alone at a driven temperature for 10 minutes, the measurement should be executed. Measurement should be executed in a stable, windless, and dark room. Optical specifications are measured by Topcon BM-7 luminance meter 1.0° field of view at a distance of 50cm and normal direction.

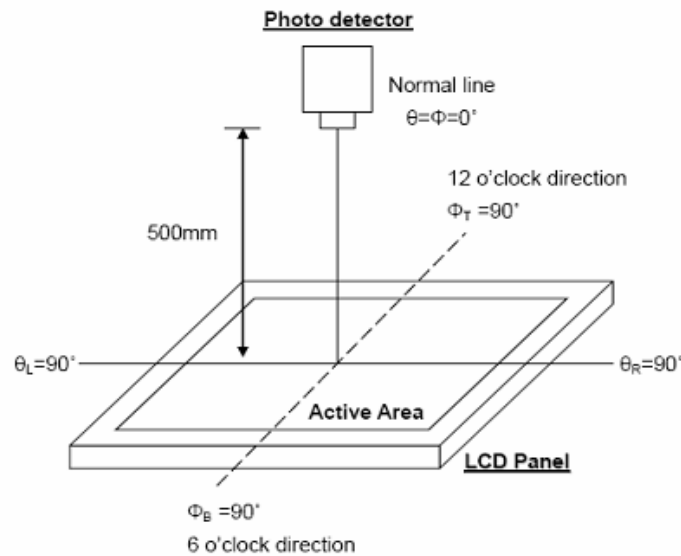

Fig. 8-2 Optical measurement system setup

(3) Definition of Response time:

The response time is defined as the LCD optical switching time interval between “White” state and “Black” state. Rise time, T_r , is the time between photo detector output intensity changed from 90% to 10% . And fall time, T_f , is the time between photo detector output intensity changed from 10% to 90% .

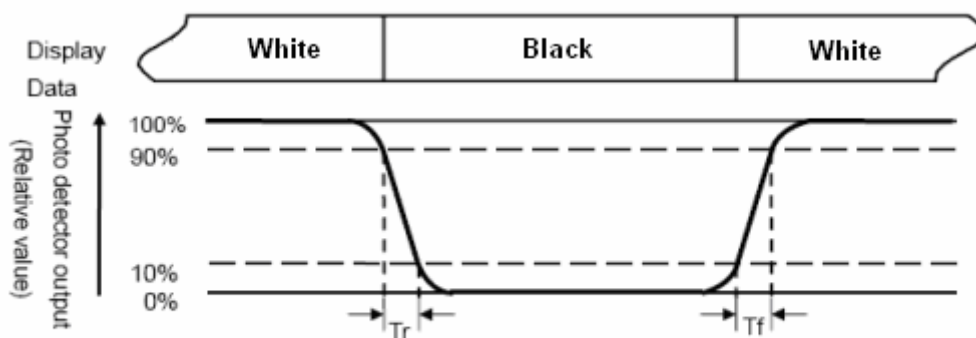

Fig. 8-3 Definition of response time

(4) Definition of contrast ratio:

The contrast ratio is defined as the following expression.

$$\text{Contrast ratio (CR)} = \frac{\text{Luminance measured when LCD on the "White" state}}{\text{Luminance measured when LCD on the "Black" state}}$$

(5) Definition of color chromaticity (CIE 1931)
Color coordinates measured at the center point of LCD

(6) Measured at the center area of the panel when all the input terminals of LCD panel are electrically opened.

$$(7) \text{ Uniformity (U) } = \frac{\text{Brightness (min)}}{\text{Brightness (max)}} \times 100\%$$

8. INTERFACE

8.1 LCM PIN Definition

Pin No.	Symbol	Description	Remark
1	GND	Power Ground	
2	GND	Power Ground	
3	NC	Not Connect	
4	Vcc	Power Supply for Digital Circuit	
5	Vcc	Power Supply for Digital Circuit	
6	Vcc	Power Supply for Digital Circuit	
7	Vcc	Power Supply for Digital Circuit	
8	NC	Not Connect	
9	DE	Data Enable	
10	GND	Power Ground	
11	GND	Power Ground	
12	GND	Power Ground	
13	B5	Blue Data 5 (MSB)	
14	B4	Blue Data 4	
15	B3	Blue Data 3	
16	GND	Power Ground	
17	B2	Blue Data 2	
18	B1	Blue Data 1	
19	B0	Blue Data 0 (LSB)	
20	GND	Power Ground	
21	G5	Green Data 5 (MSB)	
22	G4	Green Data 4	
23	G3	Green Data 3	
24	GND	Power Ground	
25	G2	Green Data 2	
26	G1	Green Data 1	
27	G0	Green Data 0 (LSB)	
28	GND	Power Ground	
29	R5	Red Data 5 (MSB)	
30	R4	Red Data 4	
31	R3	Red Data 3	
32	GND	Power Ground	
33	R2	Red Data 2	
34	R1	Red Data 1	
35	R0	Red Data 0 (LSB)	
36	GND	Power Ground	
37	GND	Power Ground	
38	CLK	Clock Signals ; Latch Data at the Falling Edge	
39	GND	Power Ground	
40	GND	Power Ground	

Note: User's connector part number is **PF050-40ZSG-F09-S** manufactured by UJU or equivalent.

9. Block Diagram

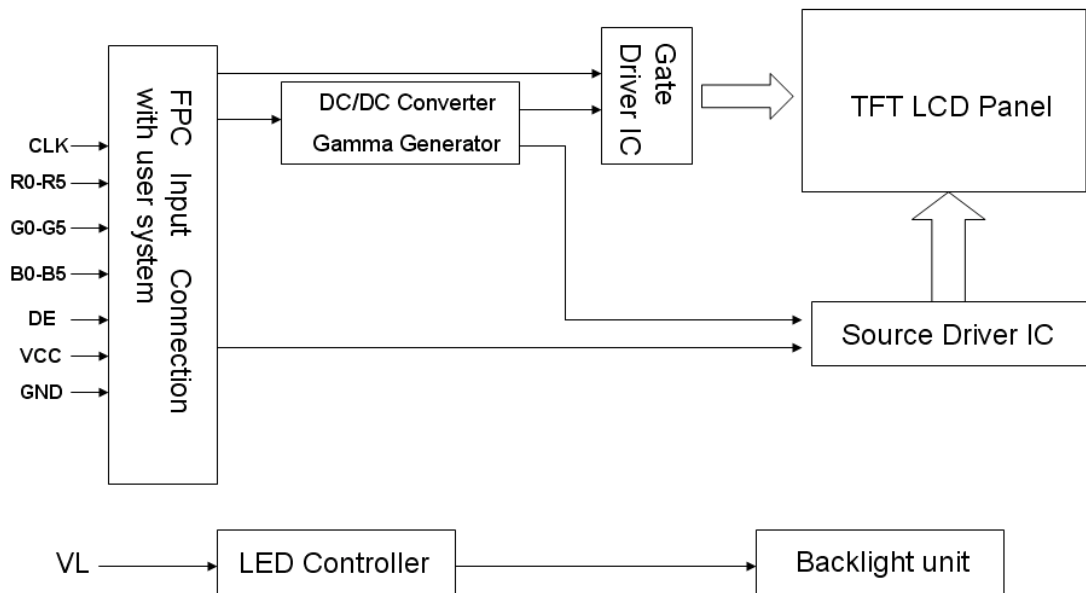

10. Quality Assurance

No.	Test Items	Test Condition	Note
1	High Temperature Storage Test	Ta=80°C Dry 240h	
2	Low Temperature Storage Test	Ta=-30°C Dry 240h	
3	High Temperature Operation Test	Ta=70°C Dry 240h	
4	Low Temperature Operation Test	Ta=-20°C Dry 240h	
5	High Temperature and High Humidity Operation Test	Ta=60°C 90%RH 240h	
6	Electro Static Discharge Test	Panel surface / top case Contact / Air : ±6KV / ±8KV , 150pF , 330Ω	Non-operating
7	Shock Test (non-operating)	Shock Level : 180G Waveform: Half Sinusoidal wave Shock Time : 2ms 3 Axis for all six faces/ each	
8	Vibration Test (non-operating)	Frequency Range: 10~500Hz/ Sweep: 1.5G Amplitude: 0.37 oct/min For 3 Axis 1hrs/axis	
9	Thermal Shock Test	-30°C(0.5Hr) ~ +80°C(0.5Hr) for 100 cycles	

Note:

- (1) The test samples have recovery time for 4 hours at room temperature before the function check. In the standard conditions, there is no display function NG issue occurred.
- (2) All the cosmetic specifications are judged before the reliability stress.

11. Outline Drawing

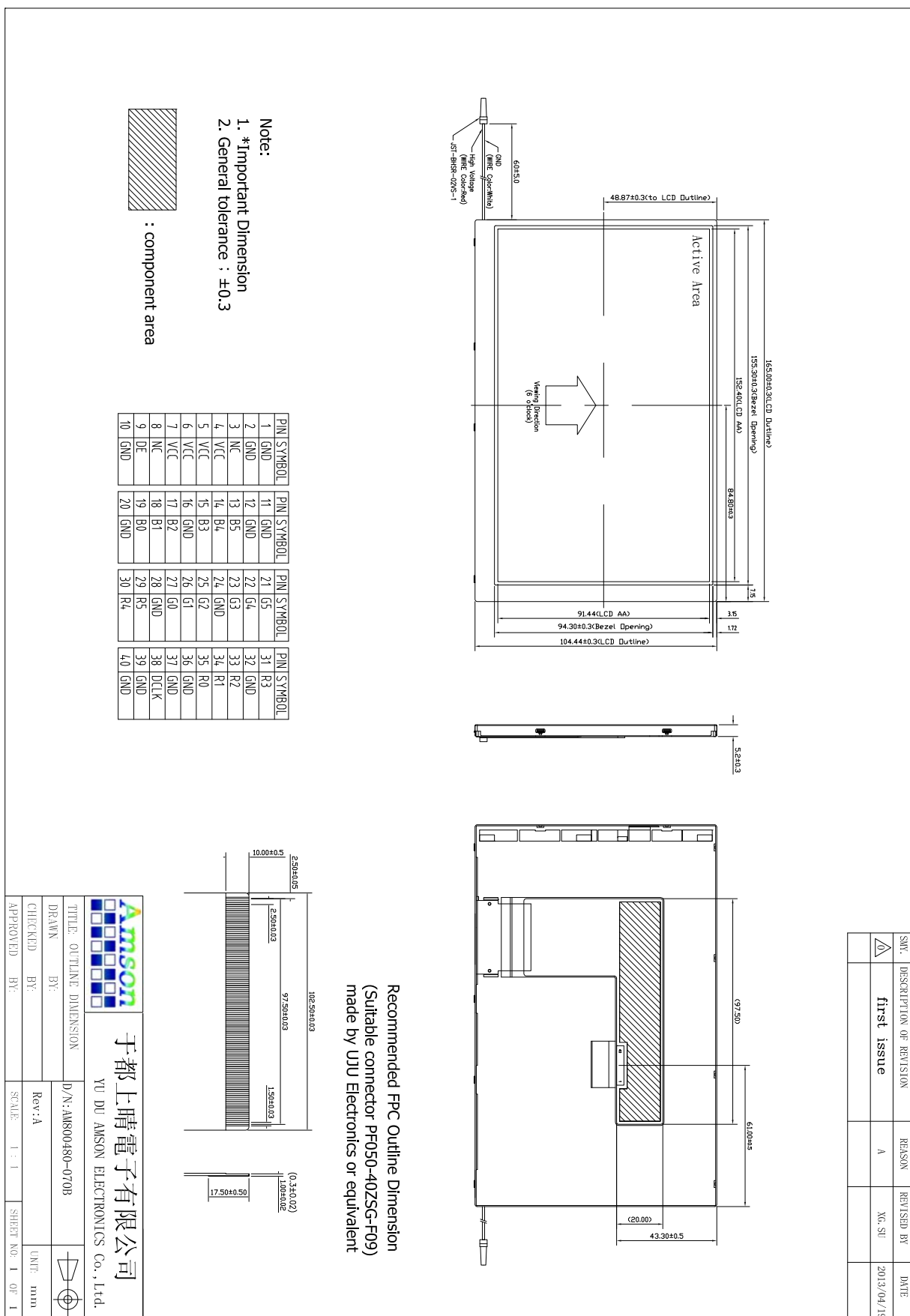

12. Precautions

Please pay attention to the following when you use this TFT-LCD module.

12.1 Mounting Precautions

- (1) You must mount a module using arranged in four corners or four sides.
- (2) You should consider the mounting structure so that uneven force (ex. Twisted stress) is not applied to the module.
And the case on which a module is mounted should have sufficient strength so that external force is not transmitted directly to the module.
- (3) Please attach a transparent protective plate to the surface in order to protect the polarizer. Transparent protective plate should have sufficient strength in order to the resist external force.
- (4) You should adopt radiation structure to satisfy the temperature specification.
- (5) Acetic acid type and chlorine type materials for the cover case are not describe because the former generates corrosive gas of attacking the polarizer at high temperature and the latter causes circuit break by electro-chemical reaction.
- (6) Do not touch, push or rub the exposed polarizers with glass, tweezers or anything harder than HB pencil lead. And please do not rub with dust clothes with chemical treatment.
Do not touch the surface of polarizer for bare hand or greasy cloth. (Some cosmetics are determined to the polarizer)
- (7) When the surface becomes dusty, please wipe gently with adsorbent cotton or other soft materials like chamois soaks with petroleum benzene. Normal-hexane is recommended for cleaning the adhesives used to attach front / rear polarizers. Do not use acetone, toluene and alcohol because they cause chemical damage to the polarizer.
- (8) Wipe off saliva or water drops as soon as possible. Their long time contact with polarizer causes deformations and color fading.
- (9) Do not open the case because inside circuits do not have sufficient strength.

12.2 Operating Precautions

- (1) The spike noise causes the mis-operation of circuits. It should be lower than following voltage : $V=\pm 200\text{mV}$ (Over and under shoot voltage)
- (2) Response time depends on the temperature. (In lower temperature, it becomes longer.)
- (3) Brightness depends on the temperature. (In lower temperature, it becomes lower)
And in lower temperature, response time (required time that brightness is stable after turned on) becomes longer.
- (4) Be careful for condensation at sudden temperature change. Condensation makes damage to polarizer or electrical contacted parts. And after fading condensation, smear or spot will occur.
- (5) When fixed patterns are displayed for a long time, remnant image is likely to occur.
- (6) Module has high frequency circuits. Sufficient suppression to the electromagnetic interference shall be done by system manufacturers. Grounding and shielding methods may be important to minimize the interference.

12.3 Electrostatic Discharge Control

Since a module is composed of electronic circuits, it is not strong to electrostatic discharge. Make certain that treatment persons are connected to ground through wristband etc. And don't touch interface pin directly.

12.4 Precautions for Strong Light Exposure

Strong light exposure causes degradation of polarizer and color filter.

12.5 Storage

When storing modules as spares for a long time, the following precautions are necessary.

- (1) Store them in a dark place. Do not expose the module to sunlight or fluorescent light. Keep the

temperature between 5°C and 35°C at normal humidity.

- (2) The polarizer surface should not come in contact with any other object. It is recommended that they be stored in the container in which they were shipped.

12.6 Handling Precautions for Protection Film

- (1) When the protection film is peeled off, static electricity is generated between the film and polarizer. This should be peeled off slowly and carefully by people who are electrically grounded and with well ion-blown equipment or in such a condition, etc.
- (2) The protection film is attached to the polarizer with a small amount of glue. Is apt to remain on the polarizer. Please carefully peel off the protection film without rubbing it against the polarizer.
- (3) When the module with protection film attached is stored for a long time, sometimes there remains a very small amount of glue still on the polarizer after the protection film is peeled off.
- (4) You can remove the glue easily. When the glue remains on the polarizer surface or its vestige is recognized, please wipe them off with absorbent cotton waste or other soft material like chamois soaked with normal-hexane.

12.7 Cautions for Installing and Assembling

Bezel edge must be positioned in the area between the Active area and View area. The bezel may press the touch screen and cause activation if the edge touches the active area. A gap of approximately 0.5mm is needed between the bezel and the top electrode. It may cause unexpected activation if the gap is too narrow. There is a tolerance of 0.2 to 0.3mm for the outside dimensions of the touch panel and tail. A gap must be made to absorb the tolerance in the case and connector.

